

QUICK START

- Requires 2 AA batteries
- Find the pyramid on the battery cover
- Push the battery cover to the right to open
- Install batteries according to polarity and replace the battery cover

Keep your fingers on the handle. Do not touch the edges of the stud finder while scanning.

QUICK TEST

- Press and HOLD the button
- Pass your finger behind the unit
- See LEDs track your finger

WATCH THE VIDEO



franklinsensors.com/instructions

Franklin Sensors Inc.
(208) 918-2403
support@franklinsensors.com

@franklinsensors

@franklinsensors

@franklinsensors

6675 N Pollard Lane
Meridian ID 83646
Hours of Operation: Monday-Friday,
8 AM to 5 PM, Mountain Time Zone

IMPORTANT: READ BEFORE USING. SAVE THESE INSTRUCTIONS.

Operating/Safety Instructions

FRANKLIN SENSORS PROSENSOR X2100 & M210

Congratulations on selecting a Franklin Sensors stud finder – the most advanced wall sensing technology on the market. Your ProSensor incorporates advanced technology that precisely senses the surface in multiple locations simultaneously, then instantly identifies the location(s) of hidden object(s). It is quick, easy and accurate.

SAFETY RULES FOR THE PROSENSOR X2100 & M210

WARNING: Read all instructions before use. Failure to follow safety instructions may result in electric shock, fire, and/or serious injury and death.

WARNING: It is possible that there may be wood, metal, wiring, or other objects behind the surface that are not detected. The stud finder may also detect pipes, wires, or other objects. The stud finder is designed to detect any change in density but does not identify what type of object it detects. The illuminated LEDs may indicate the location of many different features including, but not limited to, studs, beams, water pipes, gas pipes, wires, an inconsistency in the surface material or paint, etc.

WARNING: TURN OFF all gas, water, and electric power before using any drilling or penetrating the wall.

FAILURE TO TAKE THESE AND OTHER NECESSARY PRECAUTIONS COULD RESULT IN ELECTRIC SHOCK, FIRE, AND/OR SERIOUS INJURY AND DEATH.

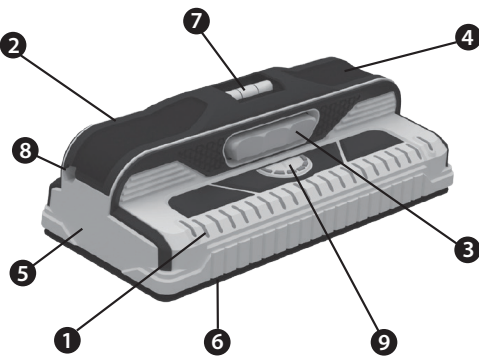

- LED Lights
- Ergonomic Handle
- "On" Button
- Battery Cover
- Detector Housing
- Sensor Board
- Bubble Level
- Pencil Caddy
- Live Wire Meter

OPERATING INSTRUCTIONS

Para instrucciones en español, visite <https://franklinsensors.com/support/instruction-manuals/>

TO OPERATE:

- Hold the stud finder by the handle. Do not touch the detector outside of the handle area while scanning.
- With the button held down, the LEDs will quickly flow to the center, indicating that the unit has power. You may immediately begin scanning the wall. You may press the button on or off the wall. No calibration is required. As you scan, LED lights will illuminate to display the location of any hidden object.

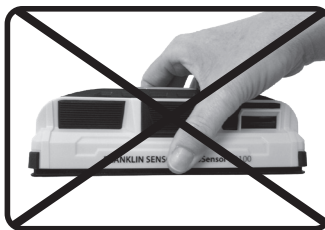
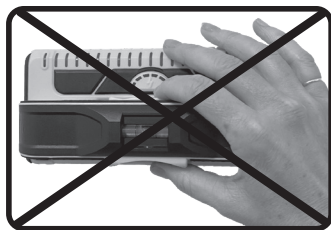
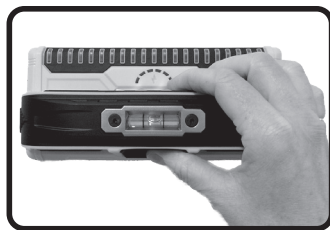

- LEDs track the center and edges of studs simultaneously. In certain models, the center LED will turn green once the precise center of the stud has been reached

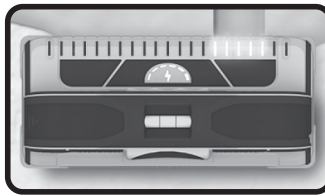
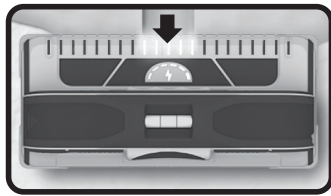
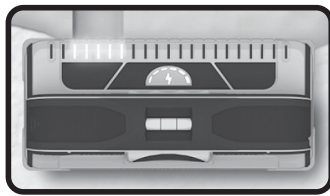

HEAVY TEXTURE OR IRREGULARITIES:

Franklin Sensors stud finders identify the location of studs by identifying differences in the density of the material in the wall. Consequently, areas of heavy texture and/or irregularities in the wall, can also cause the LEDs to illuminate. When this happens, you know your stud finder is doing its job. To help determine if you have actually found a stud, continue to press and hold the button and then scan the wall up and down. The LED lights will normally remain constant on a stud, whereas the LEDs will only display sporadically on a wall's irregularity.

FINDING PIPES AND WIRES:

Franklin Sensors stud finders identify the location of studs by identify differences in the density of the material in the wall. Consequently, wires or pipes that are near the surface, can also cause the LEDs to illuminate. When this happens, you know your stud finder is doing its job. To help determine if you have found a stud, continue to press and hold the button and then scan the wall up and down. The LED lights will normally remain constant on a stud, whereas wires may only make contact in a small area and pipes may have elbows and branch off which may cause LEDs to only illuminate sporadically. ALWAYS TAKE THE NECESSARY SAFETY PRECAUTIONS AND TURN OFF all gas, water and electric power before penetrating the wall.

LATH AND PLASTER

The ProSensor X2100 & M210 can see up to 1.7 inches and thus can see through most lath and plaster walls. When irregularities in plaster thickness and variations in construction materials exceed this depth, detection is not guaranteed. Also, the stud finder may not be able to detect if the plaster uses metal mesh reinforcement.

TILE, FLOORING, ROOFING AND EXTERIORS

Due to the variability in thickness and density in tile, roofing and exterior materials, detection is not guaranteed.

FIRE BLOCK OR HORIZONTAL STUDS

When searching for fire blocks or horizontal studs, turn the stud finder vertically and scan up and down the wall so the sensors can find the density differences in the wall.

CONVENIENT PENCIL CADDY

The ProSensor X2100 & M210 has a convenient pencil caddy. The pencil can be removed easily by gently pressing on the opening with your thumb or finger and sliding the pencil out.

BATTERIES

The ProSensor X2100 & M210 use 2 AA batteries. Do not mix old and new batteries. Do not mix alkaline, standard or rechargeable batteries.

REPLACING THE BATTERIES

- Remove the battery cover by pushing on the recessed triangle on the right and lift.
- Replace with 2 new AA batteries.
- Close the unit by replacing the battery cover and sliding it to the left until it snaps into place.

When the battery voltage is low, the second LED from the right will flash. Replace with 2 new batteries.

LIVE WIRE METER

The ProSensor LIVE WIRE METER™ works continually while the button is depressed. When a live electrical wire is detected, the yellow LEDs on the Live Wire Meter will illuminate in sequence as the electrical strength increases.

Live wires are most commonly found in two configurations.



- The wire runs vertically next to the stud, or
- A hole is drilled through the stud and the wire is threaded through the stud.

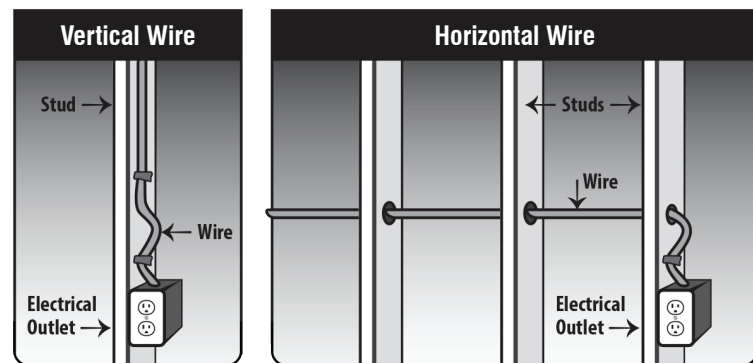

- For vertically running wires, scan the stud finder side to side.
- For horizontally running wires, run the stud finder up and down the stud.
- In both cases, the Live Wire Meter will increase in strength as you approach the live wire.

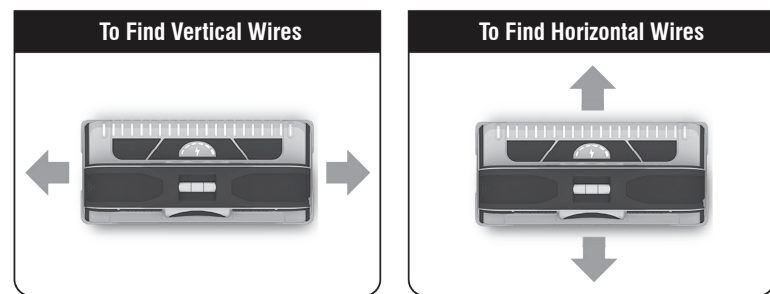

The ProSensor uses Active Learning Technology™. To best detect the presence of live electrical wires, slowly scan in both directions, passing over the same location multiple times, for a more accurate reading.

NOTE: The ProSensor LIVE WIRE METER™ is optimized for finding live wires on or near studs.

WARNING: This product may not detect all live wires or all hidden objects. Always turn off the electrical power, gas and water supplies before penetrating a surface.

TEMPERATURE

If the stud finder is subject to a significant temperature change, allow it to adjust to the ambient temperature before using. The entire area of the sensor board should be at a similar temperature for best operation.

ENVIRONMENTAL CONDITIONS

Franklin Sensors stud finders will work best when maintained in the following environmental conditions:

Storage Temperature	(0°F to 120°F) (-18°C to 50°C)
Storage Humidity	0% to 90%
Operating Temperature	Relative humidity (non-condensing) (32°F to 110°F) (0°C to 43°C)
Operating Humidity	0% to 90%

SENSING THROUGH DIFFERENT MATERIALS:

Moisture

The scanned surface should be clean and dry. Paint and wallpaper need to be completely dry before scanning for studs. It may take up to 2 weeks for wallpaper to dry enough to detect studs.

Foil-backed Insulation

Although not common, foil-backed insulation can cause inconsistent readings with all electronic stud finders, including the ProSensor.

Metallic Content in Wallpaper

Wallpaper with metallic content can block the detector's signals.

STICKERS / DECALS

Do not place decals or stickers, especially those containing metal, on the sensor board, or on the stud finder in any place.

DISASSEMBLY / TEFLON PADS

Do not disassemble the stud finder or remove the teflon pads on the bottom. The stud finder will not operate correctly without the teflon pads properly in place.

DISPOSAL

Stud finders and packaging should be sorted for recycling.

FCC PART 15 CLASS B REGISTRATION

WARNING

This device complies with Part 15 of FCC rules. Operation is subject to the following two conditions:

- This device may not cause harmful interference, and
- This device must accept any interference received, including interference that may cause undesired operation.

Changes or modifications not expressly approved by the party responsible for compliance could void the user's authority to operate this device.

NOTE: This equipment has been tested and found to comply with the limits for a Class B digital device, pursuant to part 15 of the FCC Rules. These limits are designed to provide reasonable protection against harmful interference in a residential installation. This equipment generates, uses, and can radiate radio frequency energy and, if not installed and used in accordance with the instructions, may cause harmful interference to radio communications. However, there is no guarantee that interference will not occur in a particular installation. If this equipment does cause harmful interference to radio or television reception, which can be determined by turning the equipment off and on, the user is encouraged to try to correct the interference by one or more of the following measures:

- Reorient or relocate the receiving antenna.
- Increase the separation between the equipment and receiver.
- Connect the equipment into an outlet on a circuit different from that to which the receiver is connected.
- Consult the dealer or an experienced radio/TV technician for help.

LIMITED LIFETIME WARRANTY

Franklin Sensors Inc. offers a Limited Lifetime Warranty on all its products. The products are warranted to be free from defects in materials and workmanship for the life of the product. If a defect is found, at Franklin Sensors' discretion, Franklin Sensors will either repair or replace the unit with an equivalent product.

The function of the products is not guaranteed. For example, for stud finders it is possible that there may be wood, metal, wiring, or other objects behind the surface that are not detected. It is also possible that stud finders may detect pipes, wires, or other objects that the user may not want to detect. The stud finders do not identify what type of object they detect. Illuminated LEDs may indicate the location of many different features including, but not limited to, studs, beams, water pipes, gas pipes, wires, an inconsistency in the surface material or paint, etc. This warranty does not cover incidental or consequential damage such as physical injuries, property damage, loss of time, loss of use of the product, inconveniences, or accommodations resulting from failure of the products.

Franklin Sensors shall not be liable for any special, indirect, incidental, or consequential damages or losses, whether arising from breach of warranty or based on contract, tort, reliance or any other theory. Since some countries or states do not allow limitation of the term of an implied warranty, or exclusion or limitation of incidental or consequential damages, the limitations and exclusions of this warranty may not apply to every buyer.

US Patents 8,476,912 8,593,163 8,669,772
8,736,283 8,791,708 8,836,347 8,884,633
10,895,657

US and Foreign Patents Pending.



ProSensor X2100



ProSensor M210

X2100_M210.E (10/25)

TROUBLESHOOTING

CONDITION	PROBABLE CAUSE	SOLUTION
No LED lights come on.	Weak or Rechargeable Batteries.	Replace with 2 new AA batteries. Do not mix old and new batteries.
Stud finder only works momentarily.	The "on" button isn't being held down.	Hold the "on" button down until you have completed your scan.
Difficulty starting a scan near doors and windows.	Solid headers and triple studs are often present around doors and windows. The ProSensor indicates the change in density. If all the sensors sense the same density, the LEDs will not illuminate.	Begin the scan away from the window or door, then move the stud finder to the area around the window or door. For best results, keep stud finder 3"/7cm away from wood trim, outlets, switches, etc.
The LED lights sometimes seem to light up sporadically or inconsistently.	Operator is holding the unit near the base rather than on the handle.	Only hold the unit by the handle with a finger continually pressing the button.
Inconsistent readings.	Franklin Sensors stud finders find any change in density. The sensor's job is to identify any changes in density. In the case of heavy texture, pipes and wires close to the surface of the wall, or other irregularities in the wall, the LEDs may illuminate. When this happens, you know your stud finder is doing its job!	When you get a reading, continue to press and hold the button and then scan the wall up and down. The LED lights will remain constant on a stud, while irregularities will only display temporarily.